

Cargo box / model 101 / swivel mount USER MANUAL

Product description

Read all instructions before assembly

The installation process is easier when carried out by two persons but it may be accomplished by one person

1. Bike rack pole
2. Cargo box
3. Trolley
4. Coupler
5. Swivel mount

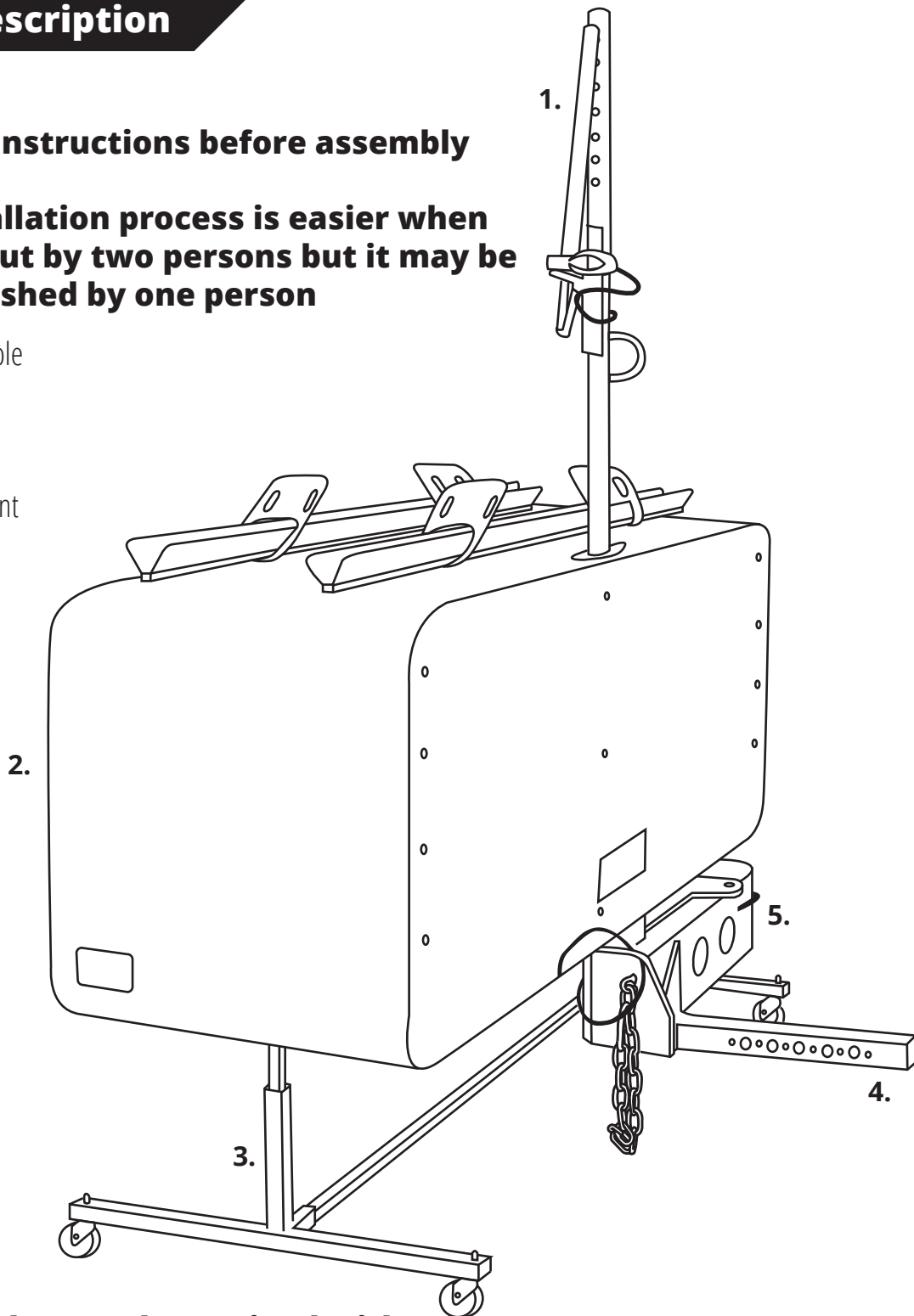

The vehicle must be equipped with a Class 3 hitch minimum, in good condition

Cargo box / model 101 / swivel mount

Parts included

1. 5/8" -11 x 1 3/4" hexagonal bolt (grade 8).
2. 5/8" heavy graded washer.
3. Retaining plate with two (2) screws.
4. Anti-vibration plate.
5. L pin.
6. Straps (8)
7. Protective rubbers

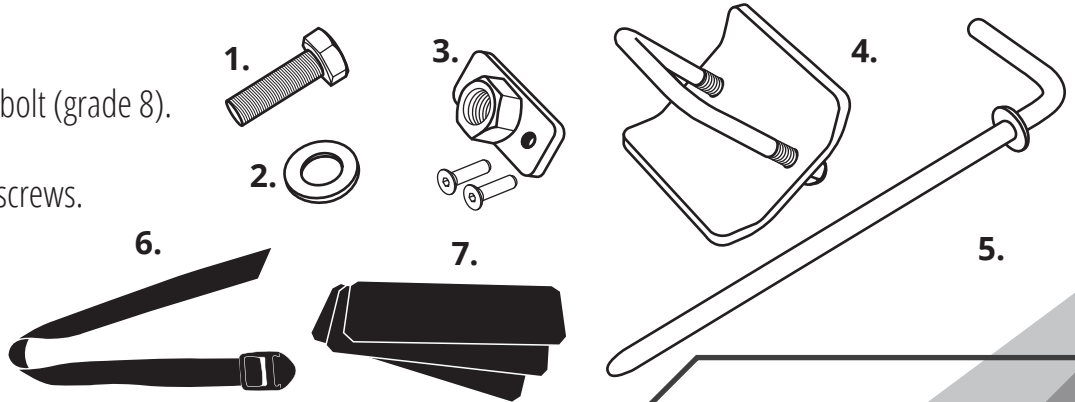

Required tools for assembly

1. Torque wrench with 15/16" and 9/16" socket (long)
2. 3/16" allen key.
3. 7/16", 1/2" and 9/16" flat wrenches.

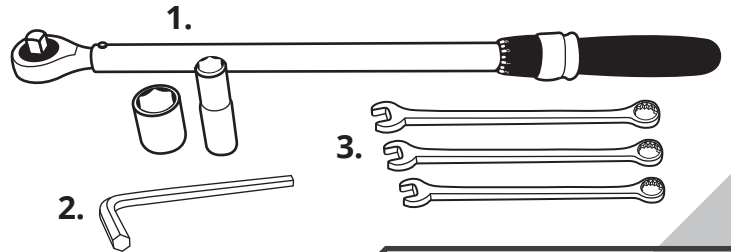

Adjustment before installation on the vehicle, if necessary

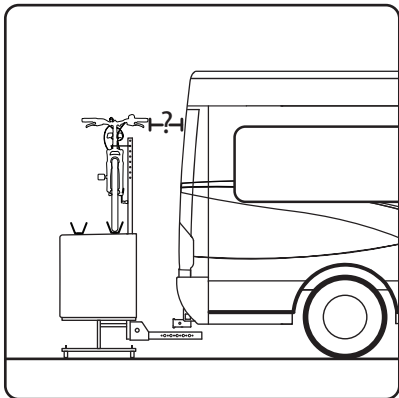

A. Position the trolley as close as possible to the vehicle keeping a safe distance between the two of them, considering the width of the bike's handlebars.

⚠ Warning! If the cargo box is too close, it could damage the vehicle.

1. Select the appropriate hole on the coupler.
2. Cut the excess length if needed. Leave at least 2 1/2" from the chosen hole.

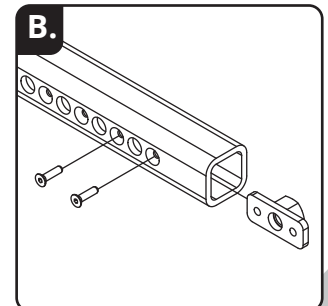
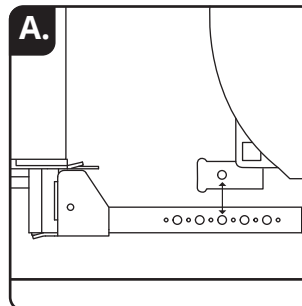

B. Insert the retaining plate inside the coupler to the appropriate hole and fix it with the two (2) screws.

Cargo box / model 101 / swivel mount

Final installation of the Cargo box on the vehicle

The installation process is easier when carried out by 2 persons but it may be accomplished by one person.

1. Make sure the vehicle is parked on a flat surface and verify that the hitch on the vehicle is clean and corrosion free.
2. Adjust the height of the trolley so that the coupler is at the same height or slightly lower than the hitch receiver.
3. Move the cargo box on his trolley towards the hitch and insert the coupler in the receiver; lift slightly if necessary.
4. Using the bike mount, slide the cargo box coupler into the receiver. Slide it until the hole on the side of the receiver and the retaining plate hole (previously installed in the coupler) are aligned.

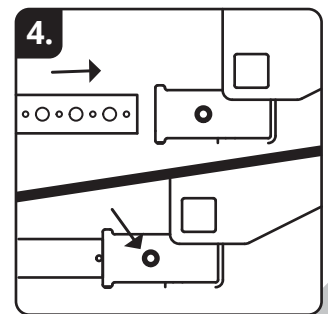
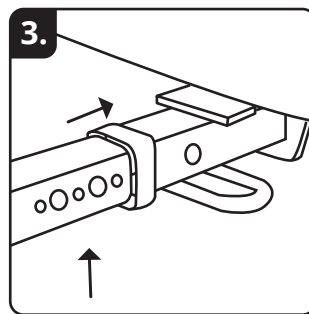
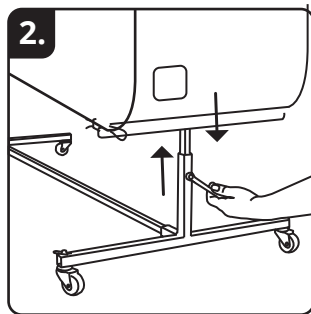
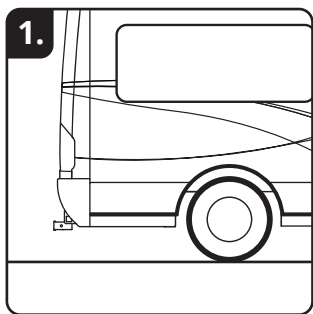

To continue the installation, it is necessary to partially open the swivel mount. To do this, you must:

- A. Remove the L pin from the back of the cargo box.
- B. Unscrew the T-handle on the front of the cargo box.
- C. Pull out the cargo box enough to have the necessary space between the box and the vehicle's bumper to complete the operations.

Warning! It is very important to keep the cargo box leveled with the trailer hitch so that operation number 5 is possible. For example, lifting the cargo box at the hinge greatly helps the operation.

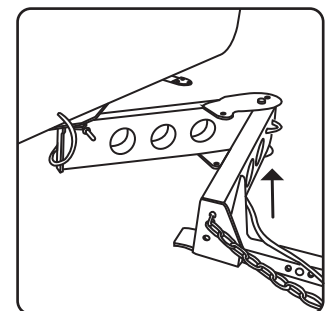
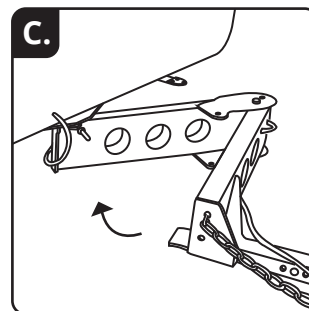
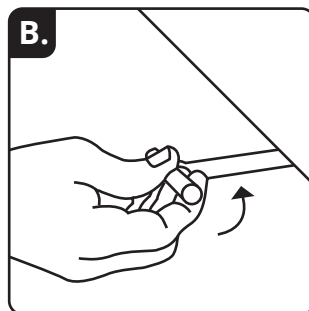
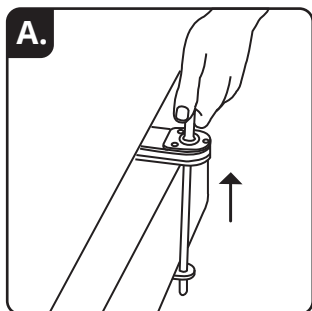

Make sure that the cargo box remains well balanced to be able to insert the bolt as shown in step 5.

Cargo box / model 101 / swivel mount

5. Insert the bolt and screw the first threads by hand (the operation must be easy).
6. Finish tightening the bolt with the torque wrench. Follow the recommendations shown on the sticker placed on the back of the cargo box.
7. Install the anti-vibration plate. Pay attention to the proper positioning of the parts.
8. Tie the chain to the vehicle to make the installation safer. You may also add a lock if desired.
9. Plug in the electrical connections and make sure everything works properly.
10. Transfer the vehicle license plate to the cargo box.

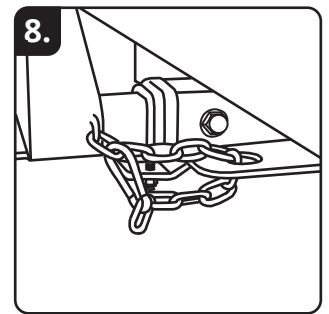
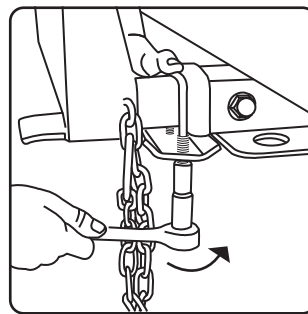
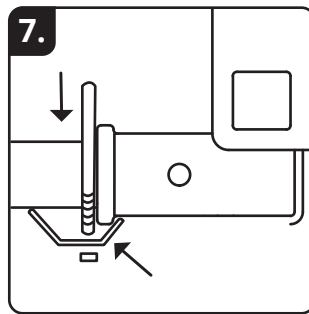
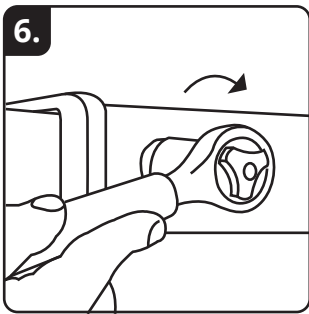
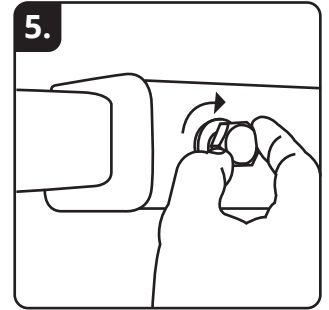

Leveling of the cargo box if necessary

1. Loosen the four (4) bolts in the inside center top of the cargo box.
2. Adjust the cargo box in comparison with the vehicle.
3. Hand tighten the four (4) bolts without exaggeration.

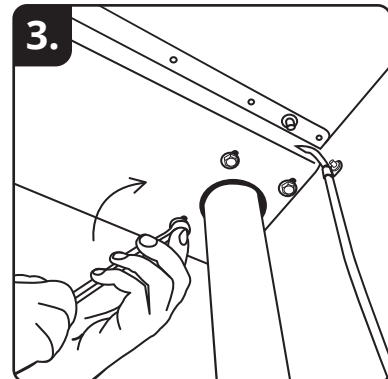
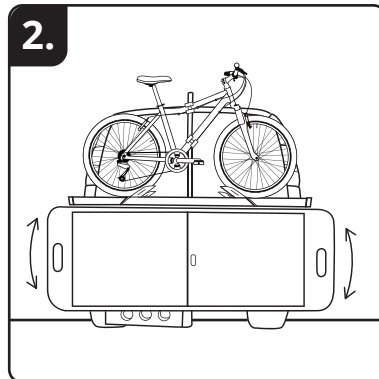
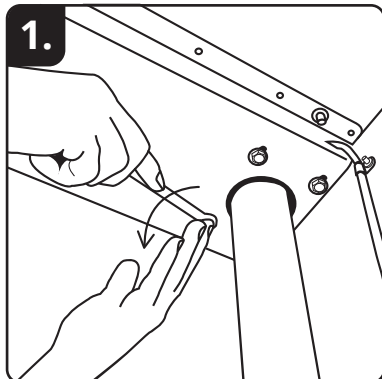

Use of the cargo box

Opening of the cargo box :

1. Always start by removing the L-pin from the back of the cargo box.
2. Unscrew the T-handle at the front of the cargo box. Unscrew until it is free from its anchor bolt.
3. Pull the cargo box straight back with the T-handle or the upper front bike rail, and rotate it to the side of the vehicle.
4. When the cargo box is perpendicular to the mount, secure it with the small pin located on the mount.
5. Finally, the open swivel mount can be secured with the L-pin by inserting it into the hole at the joint of the hinge.

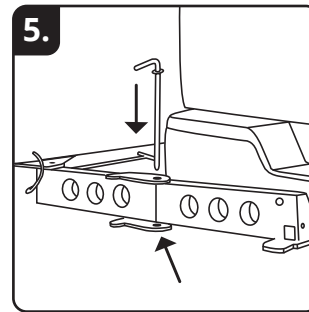
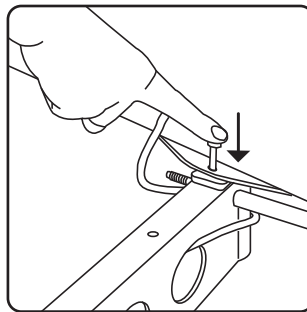
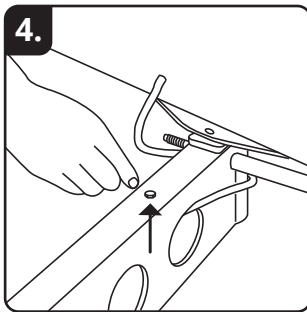

Closure of the cargo box:

1. Remove the L-pin.
2. Move the cargo box away from the vehicle. Remove the small pin and put it back in its original hole.
3. Close the swivel mount and put the cargo box back in place by pushing it using the upper front bike rail or the T-handle.

Be careful to evenly push the cargo box straight towards the vehicle, making sure that you don't hit it.

4. Tighten the T-handle firmly (be careful not to overtighten it). Ensure that the end of the T-handled rod sticks out from the swivel mount at the back of the cargo box (about 1/2 inch).
5. Finish by inserting the L-pin in its place at the back of the cargo box.

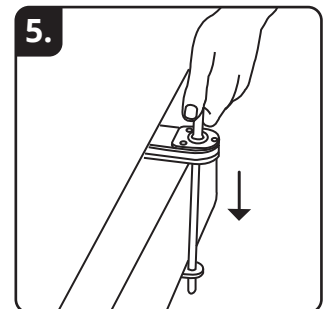

Cargo box / model 101 / swivel mount

Bikes installation on the cargo box

First, make sure that the total bike's weight does not exceed 60 lbs

1. Loosen the tire wedges with the ½ combination wrench.
2. Place the first bike in the back rack.
3. Slide and adjust the tire wedges so that they leaned well against the tires and tight them in place.

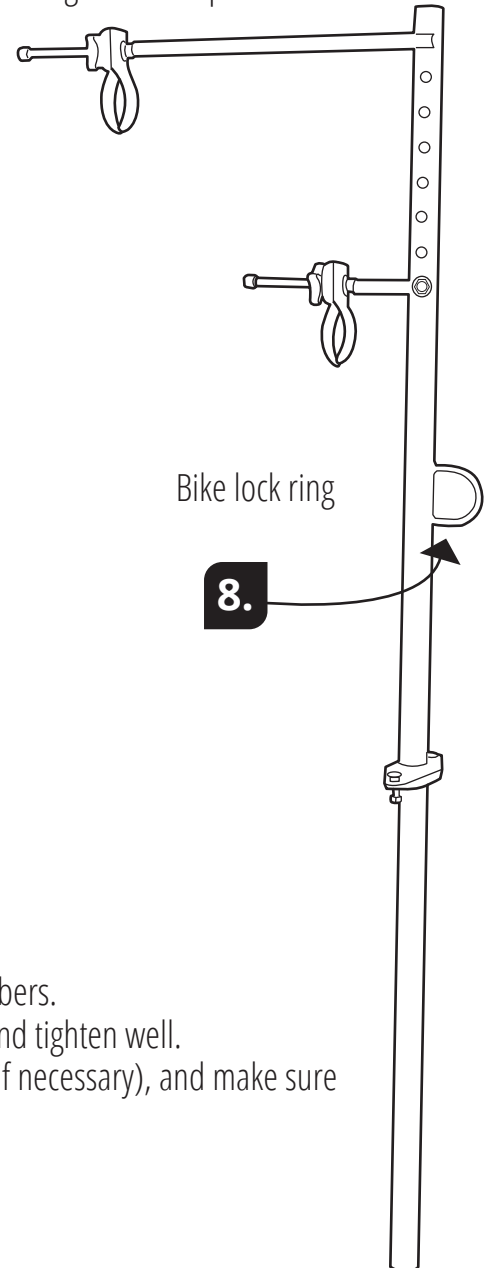
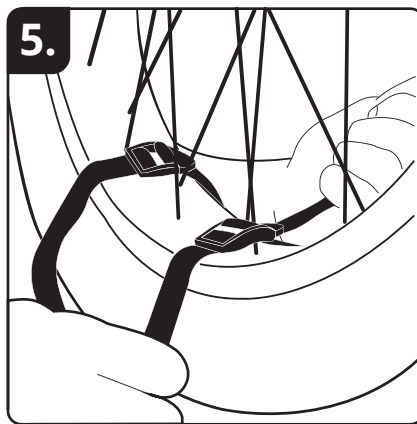
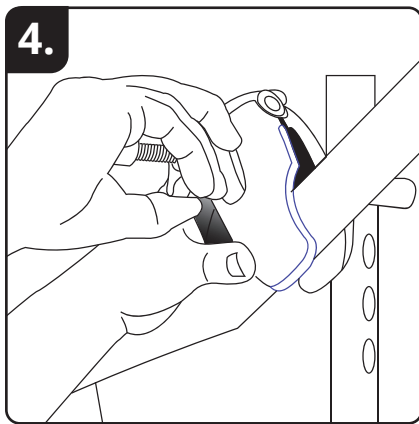
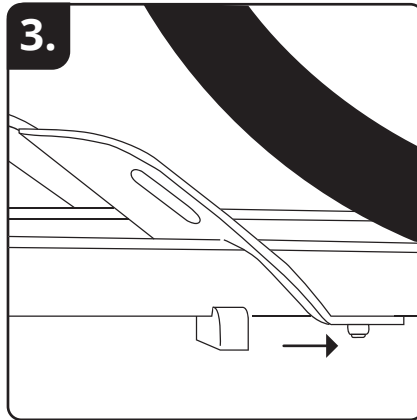
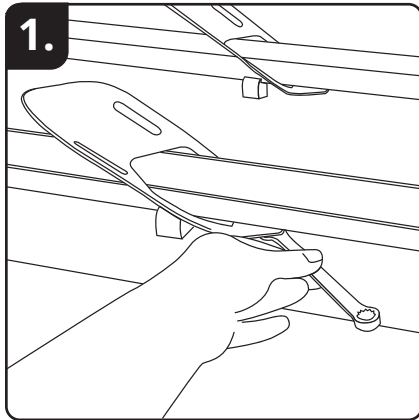

4. Fit the short plier on the bike frame (adjust the height if needed).
It is recommended to protect the frame with the provided protective rubbers.
5. Install the security straps (two per tire) around both the tires and rack, and tighten well.
6. Repeat with the second bike in the front rack, using the long plier (adjust if necessary), and make sure the handlebars are oriented on the other side.
7. Install the straps.
8. Secure the two bikes with a cable lock, using the lock ring.
9. When travelling, verify once in a while that everything stays in place.